



Flying Tiger Tuning Guide

Version 2

Our second edition of the guide comes from information we have compiled since the first 50 boats have hit the water and feedback from owners as well as on the water testing. As the class continues to grow, we will continue to test and develop sail designs to match the ongoing improvements that owners and crew are making in boat handling and equipment. With this in mind, this guide is a starting point for new and old owners alike for your Tiger program and your sailing of the boat. Both of which are sure to grow. We at Neil Pryde are excited to help you on your way.

Rig Tuning

The Tiger has a very neutral helm, as the boat is very balanced. In order to generate some weather helm and feel we set the rig with the maximum fore and aft rake. In order to achieve this, we do the following:

- ?? Set the forestay at the tack at the upper most hole in the Facnor furling plate
- ?? Position the base of the mast as far forward as possible. This will put the mast butt against the bulkhead. Note that this will require that the step be removed. You will need to remove the four lag bolts and move the step, drilling new pilot holes for the bolts.
***Note: This amount of rake is NOT paramount. There are lots of boats sailing with the mast butt in the stock position and they are no slower than butt forward boats. Rake and helm are more of a personal preference in regards to how the helm feels.
- ?? Regardless of butt position, there will be some space fore and aft at deck level. This will need to be blocked to prevent the mast from pumping
- ?? The current stock forestay length 39.69' /12100mm is from eye to eye. Add the top swivel, the drum and the tang to the top hole and all up it is 41.01' / 12500mm. If you have an early boat it might be shorter. We recommend adding a toggle to get to this length, if you are not at it. We have also experimented with increase the forestay length by another 50mm by adding a short toggle. But as the 'final' word in rake and forestay length is still yet in, these measurements are subject to change. With the boat sitting unloaded in the water and without wind, the diagram at the right shows one measurement technique for checking the rake. The main halyard is weighted and rake measured at boom height. If you use the above forestay length and butt position, you should be in this range.

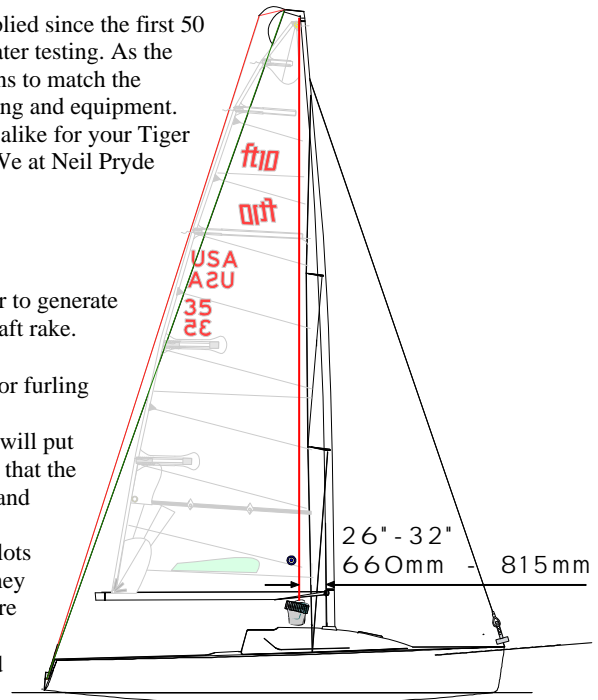

Rig Set Up

1. Note that the standing rigging is 1/4" diameter and not metric. We use a Loos PT-2 gauge for our numbers, but you can also use a PT-3. We have provided a calibration chart at the end of the guide for reference. These tensions are your base point of reference and setup for 10 knots of wind.
2. If your rig is tensioned already, soften the rig by letting shrouds off 3 full turns and release the backstay. If this is a first time set up, wind everything up hand tight. Check to see that the mast tip is centered in the boat (mast side to side) by taking a tape measure to the top of the mast with the main halyard. Swing the tape at a point along the gunwale, even with the chain plates. Note the measurement and check the opposite side. Adjust the cap shrouds to get an equal measure.
3. With the mast centered take a turn or two on each shroud, both sides evenly. Check your tensions.
4. Now take up your caps evenly on each side until you get to 1050 lbs or 35.5 on the PT2 (11.5 on PT3).
5. Tighten the lowers to 650 lbs or 30 on the PT2 (6.5 on PT3). Sight up the aft face of the mast to be sure the mast is in column side to side. Adjust as necessary to keep the mast inline, side to side.

6. Tighten the intermediates to 840 lbs or 33 on the PT2 (9 on PT3). As a general rule the intermediates should be set so that they keep the mast centered upwind in 12 knots and above, but not so tight as to take up the primary load off of the caps. In above 12 knots we like to see the tip of mast starting to bend off to leeward. You can sight the mast while sailing upwind to make sure the middle is not sagging to leeward when the tip is going off just a bit.
7. ****Note for first time boat owners, there will be a period of stretch to the standing rigging. So check and retune often until the rig settles down. Generally, wire will have an initial stretch equal to a bit over it's width over the break in period.**
8. ****Last Note: If you traditionally sail in a light air local, set the rig up softer than the base setting, as this will enhance the lower end, requiring less tuning and give you a more forgiving rig.**

Standard Class Jib Lead Position

- ?? The pin on the genoa lead car should be aft of the sheave.
- ?? All-purpose setting should have 20 holes showing in front of the car. The front of the car should be 27" / 685mm aft of the front of the track.
- ?? Light air move forward one to two holes depending on conditions.
- ?? Heavy air move car back one hole.

Sail Trim

The Tiger sailplan is very powerful and the boat is quick to come to speed and in you will find that in 12 knots you will be starting to depower the sailplan depending on crew weight. Mainsail trim is key to upwind speed in, with an emphasis on twist. It is important to watch your boat speed, as this will be a quick indicator if you are sailing with the main too free (low) or too tight (high). Use the Rig Tension sheet to setup the rig tension based on wind strength and the Polar Chart for your upwind targets.

Air: Less than 6 knots

Mainsail: Traveller should be 12" / 300mm to weather of centerline and the sheet eased enough to have the boom below centerline 7-9" / 176-230mm below centerline. This will keep the leech of the main open and the slow moving air attached. Backstay should be completely off and the outhaul eased 2-3" / 50-76mm.

Jib: Light air lead position, soft halyard and leech open.

Air: 6-8 knots

Mainsail: Mainsail sheet brought in to bring boom to centerline and the top telltale should be just starting to stall.

Jib: Sheet tension increases to bring leech in.

Air: 8-10 knots

Mainsail: Traveller lowered so it is between 6-8" / 150-200mm above centerline. Mainsheet tightened additionally. The boom should be at centerline. It is easy to over trim the leech of the main in this condition, so keep an eye on the top telltale and make sure it is not stalling too much. Backstay should be just brought on to help with forestay tension. Outhaul brought in so it is 1-2" / 25-50mm from max.

Jib: Move lead aft to Medium setting, increase halyard tension to remove any luff wrinkles and bring the leech in so that the top leech telltale is streaming.

Air: 10-12 knots

Mainsail: Traveller should be between 6-8" / 150-200mm above centerline. Mainsheet brought to obtain height to windward. The boom should be at centerline. Backstay brought on to increase tension and start to flatten upper third of mainsail. Cunningham tightened to bring draft forward and keep the leech open. Outhaul should be within 1" / 25mm of max.

Jib: Lead at Medium setting; increase halyard tension to keep draft forward and round entry.



*Reference photo of pre-bend set up to listed specifications.
Note very straight section from mid-mast down.*



Air: 12-15 knots

Mainsail: The traveller is set to centerline and backstay on tight to flatten upper sections of mainsail. The backstay should now be played in the puffs to open the leech and increase the rig tension, keeping the jib from becoming too full. Mainsheet played continuously through the puffs making sure not to stall the upper telltale. The main should be flat and open up top with the lower leech firm to help with pointing. Cunningham tightened hard to bring draft forward and keep the leech open. Outhaul should be brought all the way on. Boom vang tightened to remove any slack.

Jib: Lead at Heavy setting; increase halyard tension to keep draft forward and round entry. Leech may need to be opened up in puffs.

Air: Above 15 knots

Mainsail: The traveller below centerline but played in the lulls. Boom vang brought on tight to keep leech tension on the main during strong puffs.

Jib: Switch to your Neil Pryde No.2 jib

NP Heavy Jib Lead Position

- ?? The pin on the genoa lead car should be aft of the sheave.
- ?? All-purpose setting should have 14 holes showing in front of the car. This will be about 19.25" /488mm aft of the front of the track.
- ?? Lulls or soft spots move the car forward one hole.
- ?? De-power mode air move car back one hole.

| Loos Calibration / Reference | | | |
|-------------------------------------|----------------------------|--------------------------------|--------------------------------|
| Shroud | LBS / KG | Scale: PT-2 ¼" Wire | Scale: PT-3 ¼" Wire |
| Lower | 780/ 272 | 29 | 6 |
| | 660 / 300 (<i>Base</i>) | 30 | 6.5 |
| | 700 / 318 | 31 | 7 |
| Intermediate | 780/ 354 | 32 | 8 |
| | 840 / 381 (<i>Base</i>) | 33 | 9 |
| | 900 / 409 | 34 | 10 |
| Caps | 1000 / 454 | 35 | 11 |
| | 1050 / 477 (<i>Base</i>) | 35.5 | 11.5 |
| | 1200 / 455 | 37 | 13 |

| Rig Tension Guide | | | | |
|--------------------------|------------|---------|-------------|----------------|
| 0-6 knots | 8-10 knots | 10 Knot | 12-14 knots | Above 14 knots |
| -2 Turns | -1 Turn | Base | +1 Turn | +2 Turns |

| Target Upwind Boat Speed* | |
|----------------------------------|-------------------|
| True Wind Speed | Boat Speed |
| 6 | 5.50 |
| 8 | 6.00 |
| 10 | 6.25 |
| 12 | 6.36 |
| 14 | 6.41 |
| 16 | 6.53 |

*These numbers are from VPP's and being a light sport boat, the numbers/boat are affected more so by waves; both in light air and heavy. In these varying conditions you will be footing for speed to get the keel and rudder working to add to lift and weather



performance or feathering the boat...sSo depending on conditions you may see higher numbers, wider angles but within the right VMG range.